

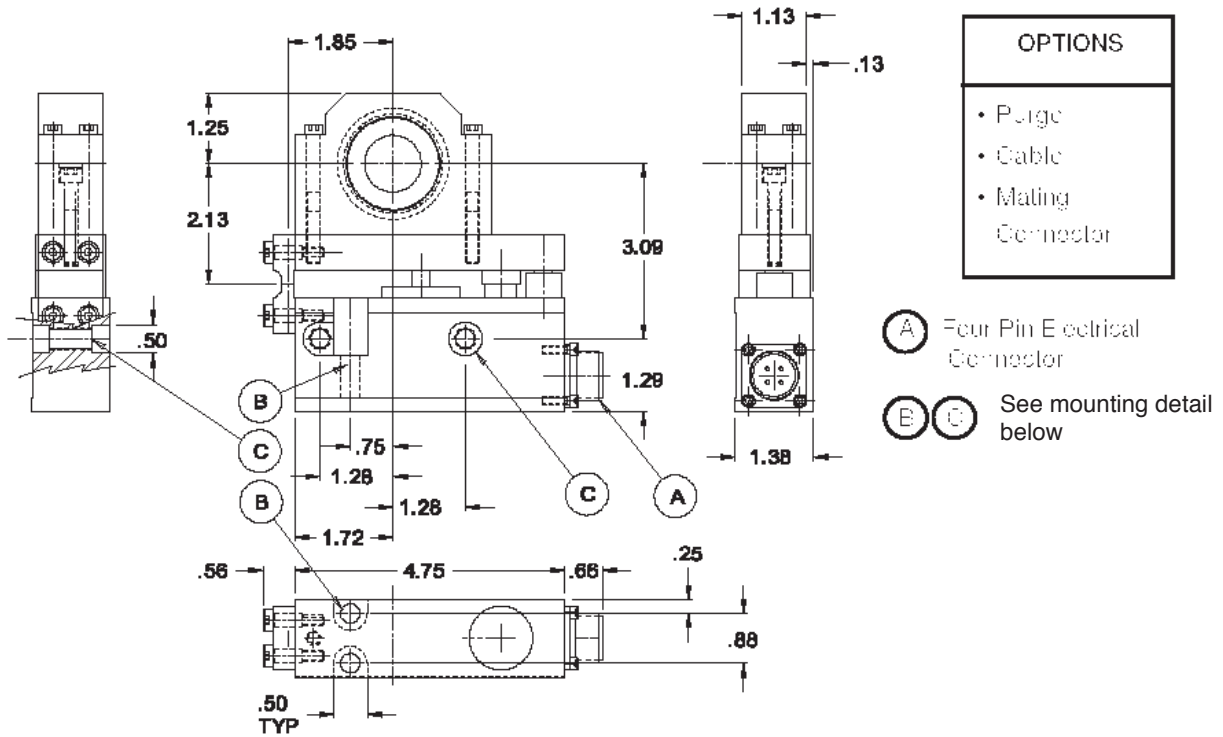

# B20 NON-ROTATING SHAFT MOUNTING

MODEL B20	CAPACITY RANGE - POUNDS						
NOMINAL	0-4	0-8	0-13	0-20	0-30	0-50	0-90
CODE	L	M	N	P	S	T	U

MODEL B30	SHAFT DIAMETER - INCHES									
INCHES	1/2	5/8	3/4	7/8	1.0	1-1/8	1-1/4	1-3/8	1-7/16	1-1/2
CODE	8	10	12	14	16	18	20	22	23	24



## Mounting Detail B & C

### Base Mount

11/32 (.344) diameter hole to receive 5/16 diameter socket head cap screw. Two (2) required.

### Wall Mount

Q (.322) diameter hole with counterbore for recessed head to receive 5/16 diameter socket head cap screw. Two (2) required for Wall Mount. Hole also tapped for Alternate Reverse Wall Mount to receive 3/8-24 UNF bolt. Two (2) required.