

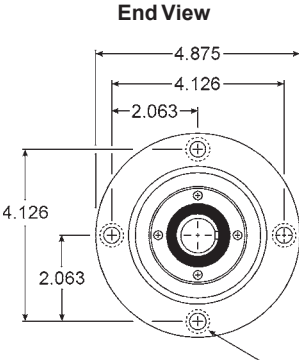
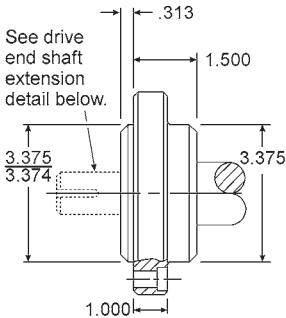
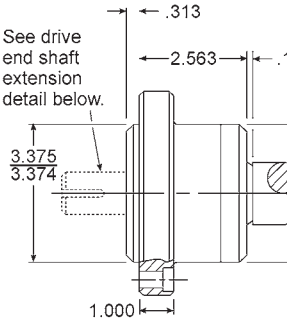
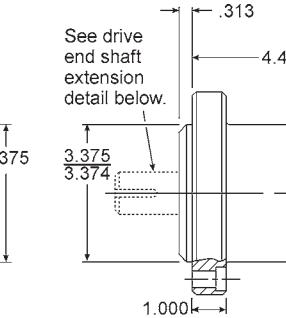
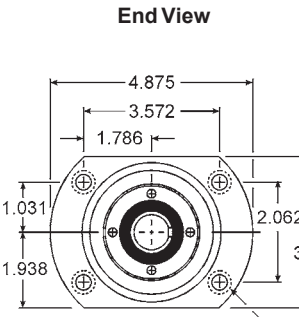
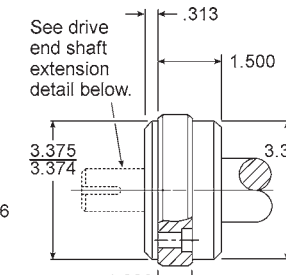
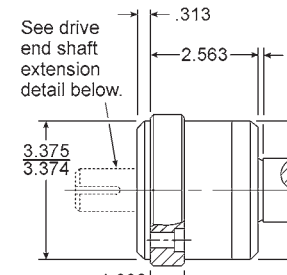
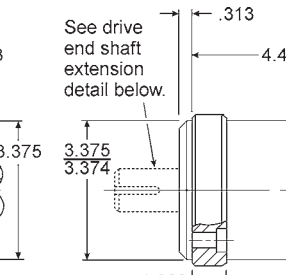

COMPTROL BEARING BLOCKS FOR 1.500 DIAMETER BALLSCREWS

Flange Mount	Model	Shaft End	Model	Shaft End	Model	Shaft End
 <p>End View</p> <p>See mounting hole detail.</p>	66-204-A	Driven	66-204-B	Driven	66-204-C	Driven
	66-204-A1	Non-Driven	66-204-B1	Non-Driven	66-204-C1	Non-Driven
	 <p>See drive end shaft extension detail below.</p>		 <p>See drive end shaft extension detail below.</p>		 <p>See drive end shaft extension detail below.</p>	

Note: For each Type A or A1 bearing block required, add .188" to ballscrew thread length.

Cut-Off Flange Mount	Model	Shaft End	Model	Shaft End	Model	Shaft End
 <p>End View</p> <p>See mounting hole detail.</p>	66-304-A	Driven	66-304-B	Driven	66-304-C	Driven
	66-304-A1	Non-Driven	66-304-B1	Non-Driven	66-304-C1	Non-Driven
	 <p>See drive end shaft extension detail below.</p>		 <p>See drive end shaft extension detail below.</p>		 <p>See drive end shaft extension detail below.</p>	

Note: For each Type A or A1 bearing block required, add .188" to ballscrew thread length.

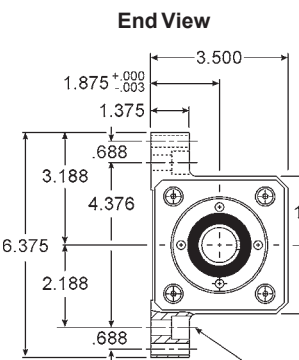
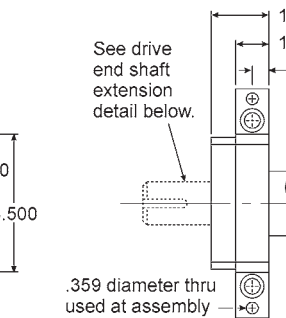
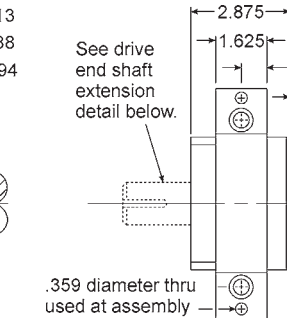
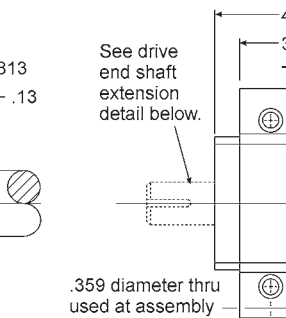
Base Mount	Model	Shaft End	Model	Shaft End	Model	Shaft End
 <p>End View</p> <p>See mounting hole detail.</p>	66-404-A	Driven	66-404-B	Driven	66-404-C	Driven
	66-404-A1	Non-Driven	66-404-B1	Non-Driven	66-404-C1	Non-Driven
	 <p>See drive end shaft extension detail below.</p> <p>.359 diameter thru used at assembly</p>		 <p>See drive end shaft extension detail below.</p> <p>.359 diameter thru used at assembly</p>		 <p>See drive end shaft extension detail below.</p> <p>.359 diameter thru used at assembly</p>	

Note: For each Type A or A1 bearing block required, add .188" to ballscrew thread length.

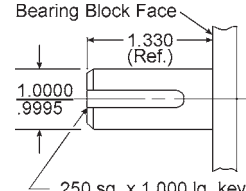
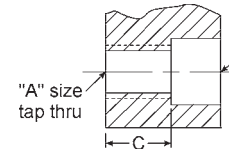
Standard Drive Extension	Mounting Hole Detail	Model Number Designation												
 <p>Bearing Block Face</p> <p>1.330 (Ref.)</p> <p>1.0000 / .9995</p> <p>.250 sq. x 1.000 lq. key</p> <p>Note: Special lengths available.</p>	 <p>"A" size tap thru</p> <p>Drilled & C'bored for "B" size socket head cap screw</p>	<p>66 - X 0 4 - X X</p> <p>Bearing Block</p> <p>Mounting Style</p> <p>2 = Flange 3 = Cut-Off Flange 4 = Base</p> <p>1.500 Diameter Ballscrew</p> <p>Shaft End Blank = Driven 1 = Non-Driven</p> <p>Bearing Type A = Radial B = Duplex C = Spaced</p>												
	<table border="1"> <thead> <tr> <th>Mounting</th> <th>A</th> <th>B</th> <th>C</th> </tr> </thead> <tbody> <tr> <td>Base</td> <td>5/8-11</td> <td>1/2-13</td> <td>0.875</td> </tr> <tr> <td>Flange & Cut-Off Flange</td> <td>7/16-20</td> <td>3/8-16</td> <td>0.656</td> </tr> </tbody> </table>	Mounting	A	B	C	Base	5/8-11	1/2-13	0.875	Flange & Cut-Off Flange	7/16-20	3/8-16	0.656	
Mounting	A	B	C											
Base	5/8-11	1/2-13	0.875											
Flange & Cut-Off Flange	7/16-20	3/8-16	0.656											

- Notes**
- All dimensions in inches unless otherwise specified.
 - Refer to Page 3 for Nominal Load Capacities.
 - End journals must be machined per dimensions on Page 13.
 - Custom and metric bearing block assemblies and/or drive end journals are available.
 - Dimensions and specifications subject to change without notice.